

# ELECTRONICALLY CONTROLLED AIR SUSPENSION (ECAS) FOR TRUCKS

## MAINTENANCE MANUAL



MM36

**WABCO**



# Table of Contents

## Table of Contents

<b>1</b>	<b>General Information.....</b>	<b>5</b>
1.1	Symbols Used in this Document.....	5
1.2	How to Obtain Additional Maintenance, Service and Product Information.....	6
1.3	How to Obtain Parts and Kits.....	6
1.4	WABCO TOOLBOX PLUS™ Software.....	6
1.5	WABCO Academy.....	6
1.6	WABCO Online Product Catalog.....	6
1.7	Your Direct Contact to ZF CVS.....	7
<b>2</b>	<b>Safety Information.....</b>	<b>8</b>
2.1	Provisions for a safe work environment.....	8
<b>3</b>	<b>Introduction.....</b>	<b>9</b>
3.1	Contents.....	9
3.2	Overview.....	9
3.3	Components.....	10
3.4	Height Sensor.....	11
3.5	Solenoid Valve Unit.....	11
3.6	Vehicle Speed Sensor.....	12
3.7	Lamps.....	12
3.8	Switches.....	12
3.9	Remote Control Unit.....	13
<b>4</b>	<b>Operation.....</b>	<b>14</b>
4.1	System Functions.....	14
<b>5</b>	<b>Troubleshooting and Testing.....</b>	<b>17</b>
5.1	Hazard Alert Messages.....	17
5.2	ABS Faults.....	17
5.3	ECAS FAIL Indicator Lamp.....	17
5.4	WABCO Test Adapter for ECAS.....	18
5.5	WABCO Diagnostic Controller.....	21
<b>6</b>	<b>Wiring Diagrams.....</b>	<b>23</b>
6.1	System Configuration Layouts.....	23

**Edition 1**  
**Version 2 (02.2022)**  
**MM36 (en)**

This publication is not subject to any update service. Information contained in this publication was in effect at the time the publication was approved for printing and is subject to change without notice or liability. ZF CV Systems North America LLC reserves the right to revise the information presented or to discontinue the production of parts described at any time.

You will find the current edition at: <https://zf.com/cvliterature>

# General Information

## 1 General Information

### 1.1 Symbols Used in this Document

#### **DANGER**

Description of an immediate situation which will result in irreversible injury or death if the warning is ignored.

#### **WARNING**

Description of a possible situation which may result in irreversible injury or death if the warning is ignored.

#### **CAUTION**

Description of a possible situation which may result in irreversible injury if the warning is ignored.

#### **NOTICE**

Description of a possible situation which may result in material damage if the warning is ignored.

 Important information, notices and/or tips

 Reference to information on the Internet

Descriptive text

– Action step

1. Action step 1 (in ascending order)

2. Action step 2 (in ascending order)

⇒ Result of an action

• Listing

 Indicating the use of a tool / WABCO tool

## General Information

### 1.2 How to Obtain Additional Maintenance, Service and Product Information

If you have any questions about the material covered in this publication, or for more information about the WABCO product line, please contact WABCO Customer Care Center at 855-228-3203, by email at [wabconacustomercenter@zf.com](mailto:wabconacustomercenter@zf.com), or visit our website: [www.zf.com/cv](http://www.zf.com/cv).

Refer to the Society of Automotive Engineers (SAE) website to find all current SAE documents and standards applicable to WABCO products (such as SAE J447 and SAE J908 at [www.sae.org](http://www.sae.org)).

Refer to the National Highway Traffic Safety Administration (NHTSA) website to find all current documents referenced in the manual at [www.nhtsa.gov](http://www.nhtsa.gov).

### 1.3 How to Obtain Parts and Kits

Contact the WABCO Customer Care Center at 855-228-3203 (United States and Canada); 800-953-0248 (Mexico). Email: [wabconacustomercenter@zf.com](mailto:wabconacustomercenter@zf.com).

### 1.4 WABCO TOOLBOX PLUS™ Software

TOOLBOX PLUS™ Software provides PC diagnostic for WABCO products and can be purchased and downloaded from <https://wabco.snapon.com>.

The software User Guide, MM19047 can be obtained by visiting our Literature Center.



Purchase and Download TOOLBOX PLUS™

<https://wabco.snapon.com>



ZF Commercial Vehicle Literature Center

<https://zf.com/cvliterature>

### 1.5 WABCO Academy



[www.wabco-academy.com](http://www.wabco-academy.com)

### 1.6 WABCO Online Product Catalog



[www.wabco-customercenter.com](http://www.wabco-customercenter.com)

## General Information

### 1.7 Your Direct Contact to ZF CVS

**ZF CV Systems North America LLC**

1220 Pacific Drive  
Auburn Hills, MI 48326

Customer Care Center: (855) 228-3203

[www.zf.com/cv](http://www.zf.com/cv)

[wabconacustomer@zf.com](mailto:wabconacustomer@zf.com)

## Safety Information

# 2 Safety Information

## 2.1 Provisions for a safe work environment

- Only experienced, trained and qualified automotive technicians may carry out work on the vehicle.
- Read this publication carefully.
- Follow all warnings, notices and instructions to avoid personal injury and property damage.
- Always abide by the vehicle's Original Equipment Manufacturer (OEM) specifications and instructions.
- Observe all accident regulations of the repair facility as well as regional and national regulations.
- The workplace should be dry, sufficiently lit and ventilated.
- Use personal protective equipment if required (safety shoes, protective goggles, respiratory protection and ear protectors).

Read and observe all Danger, Warning and Caution hazard alert messages in this publication. They provide information that can help prevent serious personal injury, damage to components, or both.

### **WARNING**

To prevent serious eye injury, always wear safe eye protection when you perform vehicle maintenance or service.

### **WARNING**

Park the vehicle on a level surface. Block the wheels to prevent the vehicle from moving. Support the vehicle with safety stands. Do not work under a vehicle supported only by jacks. Jacks can slip or fall over. Serious personal injury and damage to components can result.

### **WARNING**

This product can expose you to chemicals including Nickel, which is known to the State of California to cause cancer and birth defects or other reproductive harm. For more information, go to [www.P65Warnings.ca.gov](http://www.P65Warnings.ca.gov).



# Introduction

## 3 Introduction

### 3.1 Contents

This manual contains service information for the WABCO Electronically Controlled Air Suspension (ECAS) for 6 x 2 and 6 x 4 trucks with rear air suspensions.

### 3.2 Overview

#### 3.2.1 ECAS System

The electronically controlled air suspension system is compatible with the WABCO Antilock Braking System (ABS) and Automatic Traction Control (ATC) system, C and D versions.

Most trucks manufactured prior to March 1997 have C version ABS/ATC.

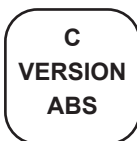

Trucks manufactured March 1, 1997 and later have D version ABS/ATC.

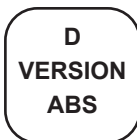

In some cases, ECAS functions differently depending upon the ABS/ATC version installed on the truck. Any differences are explained in this manual.

The electronically controlled air suspension maintains an accurate leveling of chassis height through the use of a sensor, electronic control unit (ECU) and a solenoid valve. The ECU uses sensor information to determine vehicle chassis height. If the height needs to be adjusted, the ECU controls pressure within the air bags by actuating a solenoid valve. In this way, ECAS is able to quickly adjust chassis height to a predetermined normal level. This automatic function can occur while the vehicle is in motion or stationary.

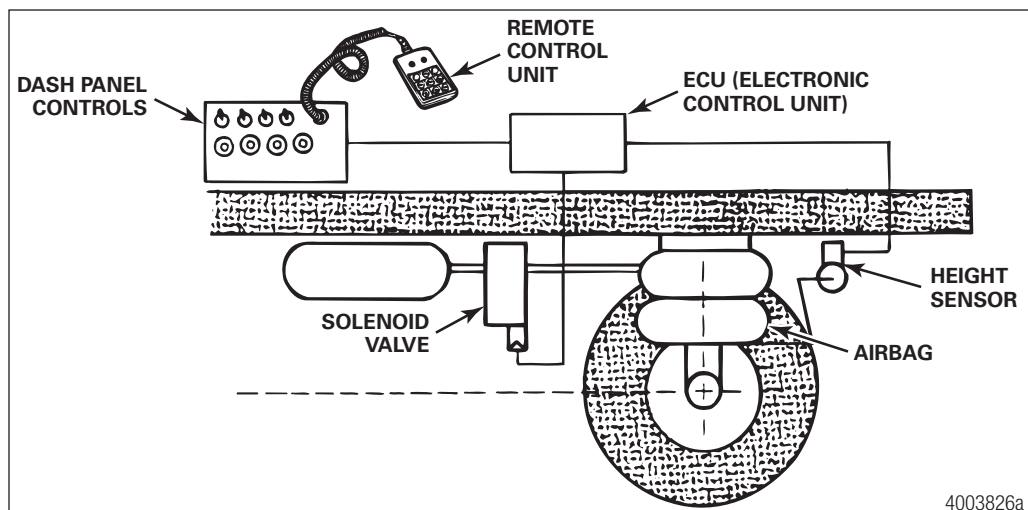

# Introduction

A remote control unit allows the vehicle operator to raise and lower the suspension within preset upper and lower stop limits. In addition to the preset upper and lower stop limits, the operator may also program two different vehicle heights into the ECAS ECU. These two selections must be between the preset upper and lower stop limits. These heights can be achieved by pushing a single button on the remote control.

ECAS provides an optional automatic load transfer feature for 6 x 2 vehicles. When a low traction situation is detected, ECAS will automatically increase traction to the drive axle by briefly decreasing pressure in the tag axle air bags. The vehicle must be equipped with WABCO ABS or ABS/ATC to activate the optional ECAS automatic load transfer feature.

The ECU also provides ECAS with self-diagnostic and reprogramming capabilities. Detected component or system failures are stored in the ECU's memory and can be retrieved using the WABCO diagnostic controller. The reprogramming feature allows the setting of preset normal, upper and lower levels, as well as other parameters. Reprogramming is done by using the WABCO diagnostic controller.

## 3.3 Components

### 3.3.1 Electronic Control Unit (ECU)

The ECU contains a microprocessor, memory, input conditioners and output drivers. A 35-pin connector links the ECU with other ECAS components, the vehicle's communication datalink and, depending upon the ECAS generation, with the ABS/ATC ECU, an additional speed sensor and the stop light switch.

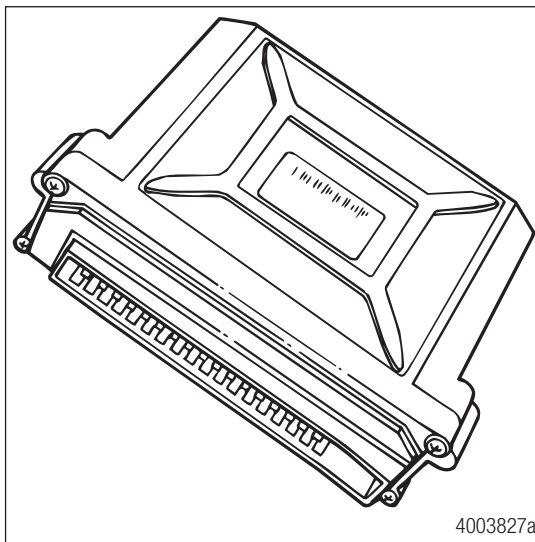

The ECU is responsible for:

- Constantly monitoring incoming signals
- Comparing the signal to nominal values stored in memory
- Determining the required controlling reaction if the actual level differs from the nominal level
- Actuating the solenoid valve unit to adjust the level
- Managing and storing index levels (normal levels, memory levels, etc.)
- Monitoring the function of all system components and storing information about any detected errors
- Receiving data from the remote control unit
- Exchanging data with the diagnostic controller

## Introduction

### 3.4 Height Sensor

A height sensor, mounted on the chassis, provides the ECU with a chassis height signal that determines the distance between the chassis and the axle. The sensor housing contains a coil in which an armature is moved up and down. The armature is connected to a lever which is attached to the drive axle housing by a linkage rod. When the distance between the chassis and the axle changes, the lever turns, causing the armature to move into or out of the coil within the sensor. This modifies the signal produced by the sensor.

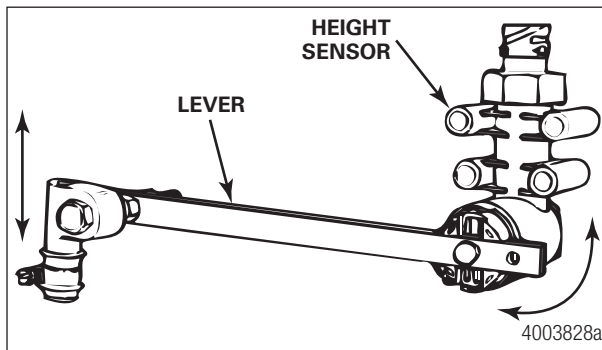

### 3.5 Solenoid Valve Unit

Special solenoid valve blocks have been developed for the ECAS system. Several solenoid valves are combined into one compact block. This saves space and reduces installation time. The solenoid valves are actuated by the ECU. The solenoids convert the voltage into a pressurizing or venting process which either increases or reduces the air volume within the air bags. If not activated, the valves are closed and maintain the air bags volume. The solenoid valve unit is usually mounted on a chassis rail. A four-pin connector links it to the ECU. The solenoid valve includes air ports to supply air or vent air from the air bags through the air lines. The configuration of the air lines and ports will vary with vehicle applications.

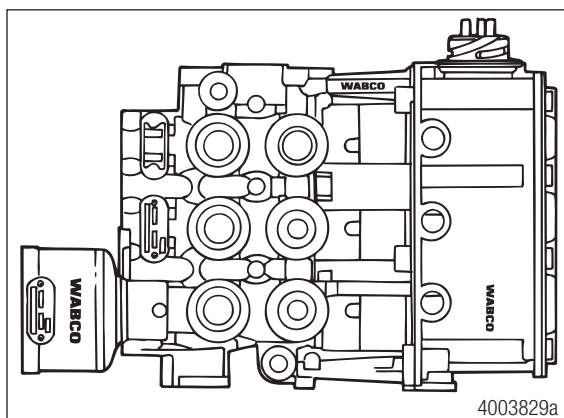

## Introduction

### 3.6 Vehicle Speed Sensor

With C version ABS/ATC, a speed sensor is mounted in the transmission tail. This sensor provides the ECU with vehicle speed information.

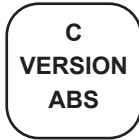

With D version ABS/ATC, the speed signal is transmitted over the communication data link (SAE J-1587).

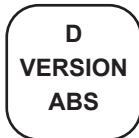

### 3.7 Lamps

A dash-mounted “ECAS FAIL” indicator lamp indicates a system fault.

A load transfer lamp displays the load transfer status. Load transfer status is explained in Section 2.

### 3.8 Switches

Either a three-position dash switch or two separate dash switches allow the operator to set the ECAS system to perform either automatic load transfer, driver activated load transfer or no load transfer.

A stop light switch signals the ECU when the brakes are applied.

## Introduction

### 3.9 Remote Control Unit

The hand-held remote control unit, or keypad, is positioned in a bracket mounted on the instrument panel. The operator uses this keypad to alter the frame height for loading and unloading. The keypad is connected to the ECU by a coiled cable and a socket on the vehicle.

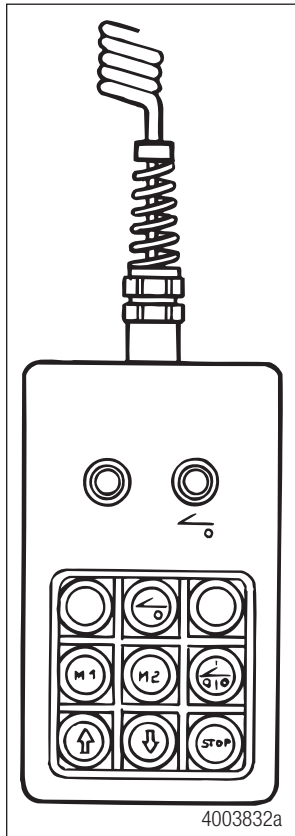

## Operation

# 4 Operation

## 4.1 System Functions

### 4.1.1 Automatic Height Control

This is the basic ECAS function. By constantly comparing the readings supplied by the height sensors with the preset heights stored in the ECU, ECAS is aware of the current height of the vehicle chassis at all times. As soon as there are any deviations exceeding a certain tolerance band, the solenoid valve is activated; and by increasing or decreasing the pressure in the air bags, the actual height is adjusted to the preset height.

If the brakes are applied, the ECU will freeze all ECAS control activities until the brakes are released.

### 4.1.2 Load Transfer (6 x 2 Vehicles)

To increase traction on a slippery road when drive axle wheel spin is detected, an automatic load transfer occurs. This transfers as much of the load as possible from the tag or pusher axle to the drive axle.

ECAS will continue to hold the transferred load for 20 seconds. After this interval, the load is transferred back to a normal condition. The transfer back to normal takes approximately 20 seconds.

If load transfer is active, all chassis height control functions are disabled until the load transfer ends.

The operator can manually activate the load transfer function by pressing the ON (momentary on) side of the load transfer switch. This manual activation only works at speeds less than 30 mph (48 km/h).

The load transfer function will terminate under the following conditions:

- Brakes are applied at a speed greater than 30 mph (48 km/h).
- Vehicle speed exceeds 70 mph (112 km/h).
- Stop button on remote control is pressed or the remote control is disconnected.

On some vehicles a load transfer indicator lamp comes on when the automatic load transfer is turned off.

# Operation

## 4.1.3 Remote Control Operation

The hand-held remote control has several functions:

- Raising and lowering the vehicle suspension
- Returning the vehicle to normal level
- Stopping all ECAS functions
- Storing and selecting two preset height levels

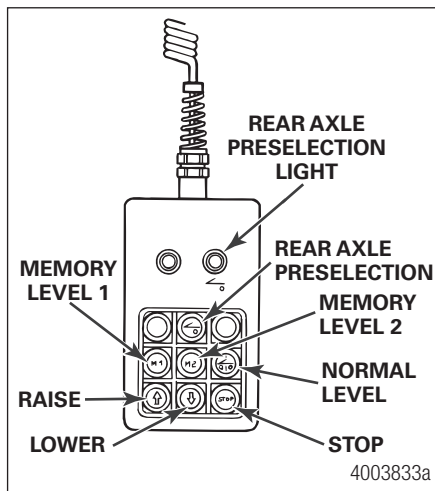

## 4.1.4 Axle Preselection

Before the remote control can be used, the rear axle must be selected for activation. Pushing the rear axle preselection key enables the level control for this axle. An acknowledgment light on the remote control indicates that the axle is selected. Pressing the rear axle preselection key a second time will disable remote control and turn off the acknowledgment light.

## 4.1.5 Raising and Lowering

The remote control unit allows the operator to change the vehicle's rear height within programmed limits. Pressing the up or down arrow keys causes the chassis height to be immediately altered. Releasing the key ends the height change. Remote control height changes can only be initiated while the vehicle is stationary or traveling at speeds less than 7 mph (11 km/h).

## 4.1.6 Normal Height

Pressing the normal height key will immediately return the chassis height to the programmed normal level.

# Operation

## 4.1.7 Setting and Selecting Memory Levels **M1** **M2**

By simultaneously pressing the STOP key and either the M1 or M2 memory keys, the current height can be stored as a memory height. Memory heights can only be stored while the vehicle is stationary.

By pressing just the M1 or M2 memory keys, the chassis height is quickly adjusted to the stored memory height. M1 or M2 height changes can only be initiated while the vehicle is stationary or traveling at speeds less than 7 mph (11 km/h).

## 4.1.8 STOP Key **STOP**

Pressing the STOP key discontinues all height control functions. This function allows the operator to discontinue any automatic height change if the continuance of the change could be hazardous. Pressing the STOP key will also discontinue the load transfer function immediately.

**i** Disconnecting the remote control performs the same functions as pressing the STOP key.

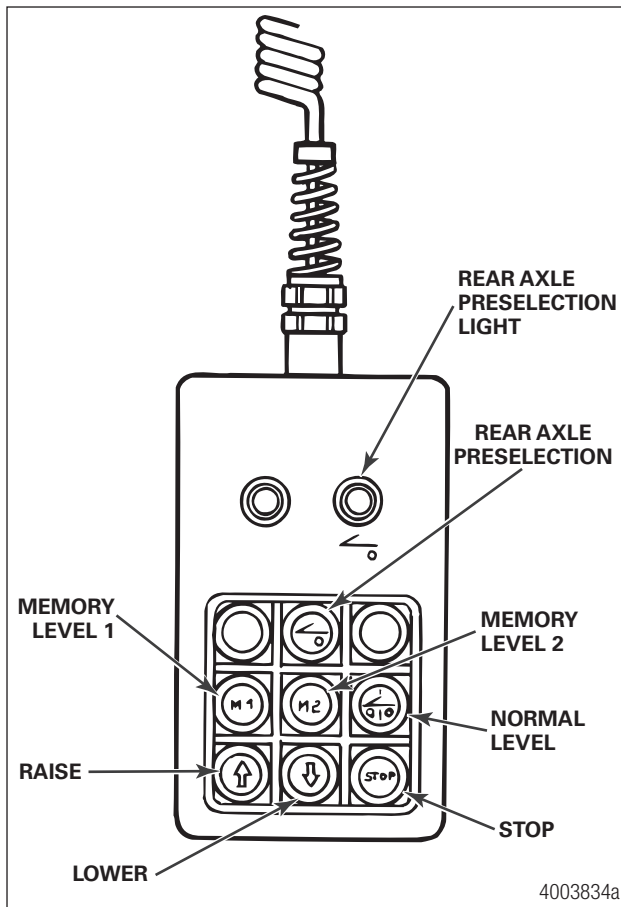



## Troubleshooting and Testing

# 5 Troubleshooting and Testing

## 5.1 Hazard Alert Messages

Read and observe all Warning and Caution hazard alert messages in this publication. They provide information that can help prevent serious personal injury, damage to components, or both.

### **WARNING**

To prevent serious eye injury, always wear safe eye protection when you perform vehicle maintenance or service.

### **WARNING**

All personnel must be clear of the vehicle before you begin to troubleshoot ECAS. Serious personal injury can result when the vehicle frame moves up and down.

## 5.2 ABS Faults

Before performing any ECAS diagnostics, make sure there are no ABS faults. Because of the interaction between the ABS and ECAS systems, a fault in the ABS system may restrict the functionality of the ECAS system.

## 5.3 ECAS FAIL Indicator Lamp

The dash-mounted “ECAS FAIL” indicator lamp indicates a system fault. When the ignition key is switched on, the lamp will come on for two seconds and then go out. This indicates there are no faults present. If the lamp does not come on at start-up, the bulb or wiring is defective.

The following failures will cause the “ECAS FAIL” indicator lamp to remain on:

- ECAS FAIL lamp wire grounded
- No power at ECU pin 1
- Electrical fault in height sensor
- Electrical fault in solenoid valve
- J1587 datalink fault
- Internal ECU fault
- Incorrect height control calibration
- Chassis height cannot be adjusted within five minutes after ignition or within 30 seconds during normal service

Depending upon the severity of the failure, the ECAS system may be partially or completely switched **OFF**.

# Troubleshooting and Testing

## 5.4 WABCO Test Adapter for ECAS

The test adapter allows troubleshooting the ECAS system by providing breakout access to the circuits contained in the 35-pin connector attached to the ECU. This allows easy Volt-ohmmeter measurement of voltage and resistance of ECAS wiring and components.

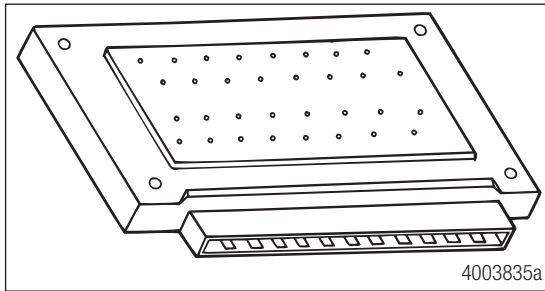

### 5.4.1 Installing the Test Adapter

1. Turn the vehicle ignition **OFF**.
2. Disconnect the 35-pin connector from the ECAS ECU.
3. Insert the test adapter into the 35-pin connector on the ECU harness.

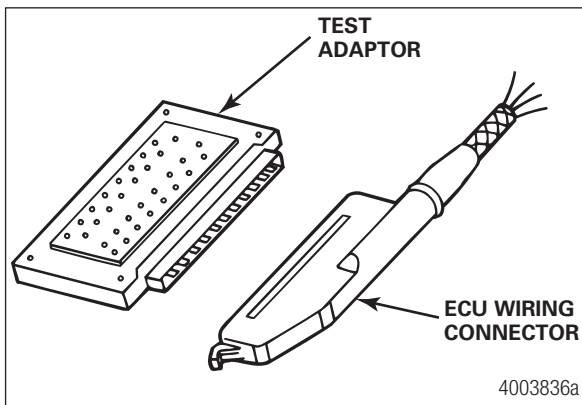

### 5.4.2 Test Instructions



Refer to the Volt-ohmmeter (VOM) manufacturer's manual for VOM operating instructions.

The following information applies to the tests presented in Table A.

1. Before you perform any of the steps listed in Table A:
  - Check the "Ignition Status" column of the table. The vehicle's ignition may be required to be either in the **ON** or **OFF** position. The engine does not have to be running.
  - Check that the air system pressure reading is between the compressor cut-in and cut-out pressure.
2. Set the VOM to the appropriate setting that will accommodate the expected readings listed in the "Measurement or Reaction" column of the table.
3. For each step in Table A, compare the VOM reading or reaction with the acceptable values or reactions listed in the "Measurement or Reaction" column. Write down the results of your comparisons.

## Troubleshooting and Testing



4. Repair or replace wiring or components when a meter reading or reaction is different than that listed in the "Measurements or Reaction" column of Table A.
5. Disconnect the test adapter.
  - If the ignition is **ON** from previous testing, turn it **OFF** before you disconnect the test adapter.
  - Reconnect the 35-pin connector to the ECU.
6. Perform a vehicle inspection. After completing the procedures in Table A and any required repairs:
  - Verify that ECAS will bring the vehicle frame to the normal ride height position. When the chassis is in this position, the instrument panel indicator lamp will go **OFF**.
  - If the indicator lamp remains **ON**, check the height sensor linkage for correct installation (refer to the vehicle manufacturer's service literature).
  - Make sure the ABS indicator lamp does not remain **ON**.

### 5.4.3 Test Adapter Guide

Table A: Testing Procedures

ECAS Power Supply					
Step	Check	Ignition Status	Adapter Pins	Measurement of Reaction	Possible Cause of Malfunction
1	Voltage to ECU	<b>ON</b> or <b>OFF</b>	1 and 27	9-15 volts DC	• Blown fuse
2	Voltage to ECU	<b>ON</b>	9 and 27	9-15 volts DC	• Power to ECU interrupted
		<b>OFF</b>	9 and 27	0 volts DC	• Constant power to ECU
ECAS Connected Features					
If vehicle is not equipped with load transfer, skip Steps 5 and 6. A second test adapter is required to test ABS ECU pin 12.					
Step	Check	Ignition Status	Adapter Pins	Measurement of Reaction	Possible Cause of Malfunction
3	Indicator lamp	<b>OFF</b>	9 and 23	Greater than 30 ohms	• Defective bulb/LED • Wiring to indicator lamp
4	Stop light switch <b>OFF</b>	<b>ON</b> or <b>OFF</b>	7 and 27	0 volts DC	• Switch broken or defective • Wiring to stoplight switch
	Stop light switch <b>ON</b>	<b>ON</b> or <b>OFF</b>	7 and 27	9-15 volts DC	
5	Load transfer switch <b>OFF</b>	<b>OFF</b>	17 and 27	Greater than 30 kilo ohms	• Switch broken or defective • Wiring to stoplight switch
	Load transfer switch <b>ON</b>	<b>OFF</b>	17 and 27	0-2 ohms	
6	Connection to ABS ECU (C version only)  <div style="border: 1px solid black; border-radius: 10px; padding: 5px; display: inline-block;">           C VERSION ABS         </div>	<b>OFF</b>	16 on ECAS and 12 on ABS	0-2 ohms	• Interrupted wiring between ECAS ECU and ABS ECU

## Troubleshooting and Testing

ECAS Height and Speed Sensors					
Step	Check	Ignition Status	Adapter Pins	Measurement of Reaction	Possible Cause of Malfunction
7	Height sensor resistance	<b>OFF</b>	25 and 27	100-140 ohms	<ul style="list-style-type: none"> <li>• Broken wire between ECU and sensor</li> <li>• Sensor connector</li> <li>• Defective sensor</li> </ul>
8	Speed sensor resistance (C version only) 	<b>OFF</b>	20 and 22	800-2,000 ohms	<ul style="list-style-type: none"> <li>• Broken wire between ECU and sensor</li> <li>• Sensor connector</li> <li>• Defective sensor</li> </ul>
9	Speed sensor resistance to ground (C version only) 	<b>OFF</b>	20 and 27 22 and 27	Greater than 30,000 ohms	<ul style="list-style-type: none"> <li>• Short between sensor and ground</li> <li>• Sensor connector</li> <li>• Defective sensor</li> </ul>
ECAS Height and Speed Sensors					
Step	Check	Ignition Status	Adapter Pins	Measurement of Reaction	Possible Cause of Malfunction
10	ECAS valve coil resistance	<b>OFF</b>	13 and 27 15 and 27 30 and 27	15-25 ohms If vehicle is not equipped with load transfer, no reading needs to be done between pins 30 and 27.	<ul style="list-style-type: none"> <li>• Interrupted wiring between ECU and valve connector</li> <li>• Ground lead to valve interrupted</li> <li>• Shorted valve coil</li> </ul>

# Troubleshooting and Testing

## 5.5 WABCO Diagnostic Controller

The WABCO diagnostic controller is an electronic diagnostic tool that is capable of communicating with the ECAS ECU.

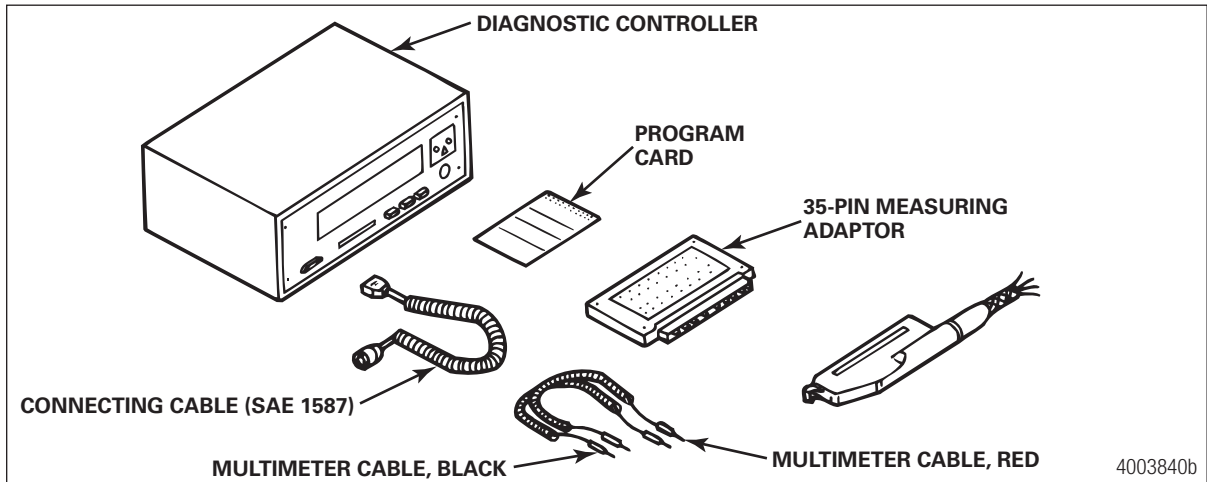

Use the controller to:

- Access ECAS system faults stored in the ECU
- Perform functionality tests on ECAS components
- Perform multimeter style voltage and resistance checks on system wiring and components
- View control equipment data stored in the ECU
- Calibrate the ECAS ECU



This manual provides a brief overview of the capabilities and operation of the diagnostic controller. For detailed instructions on using the controller, refer to the operating instructions included with the diagnostic controller.

### 5.5.1 Connecting the Diagnostic Controller

The diagnostic controller is connected to the vehicle through an SAE J1587 diagnostic plug that is wired to the ECU.

When the appropriate ECAS program card is inserted into the diagnostic controller, the controller is able to retrieve all relevant data from the ECU and perform a variety of diagnostic functions.

# Troubleshooting and Testing

## 5.5.2 Diagnostic Controller Functions

### 5.5.2.1 Failure Memory

If faults are present in the ECAS system, they are displayed in clear text on the controller screen. Also shown are the number of times the fault has occurred and whether the fault is currently present. A displayed fault that is not currently present represents an intermittent malfunction.

In order to locate the exact source of a fault, the diagnostic controller will change to the multimeter mode if necessary. The controller display screen indicates specific tests that should be performed on the ECAS wiring. Connecting an adapter to the ECU harness allows easy access to the ECAS wiring for these tests.

After successful repair of a fault, an acknowledgment is displayed on the controller screen and the fault is automatically erased from the ECU memory.

### 5.5.2.2 Component Function Tests

This feature allows specific ECAS components to be controlled and their functionality tested. Components are actuated by the diagnostic controller. If a fault is detected during the test, it is reported on the display screen.

### 5.5.2.3 Calibration

This function allows recalibration of the ECAS system when components (particularly the ECU or a sensor) are replaced.

# Wiring Diagrams

## 6 Wiring Diagrams

### 6.1 System Configuration Layouts

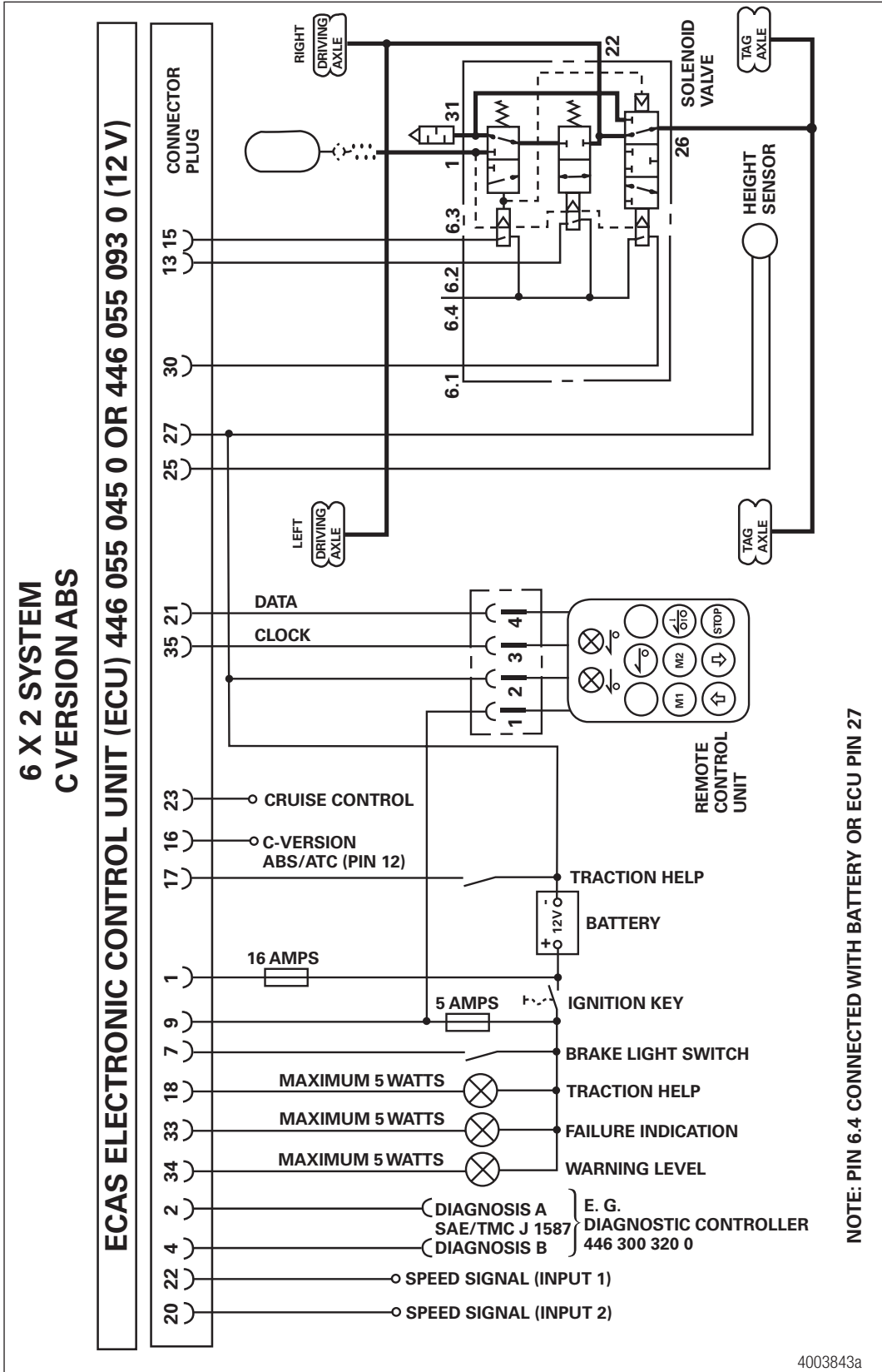

# Wiring Diagrams

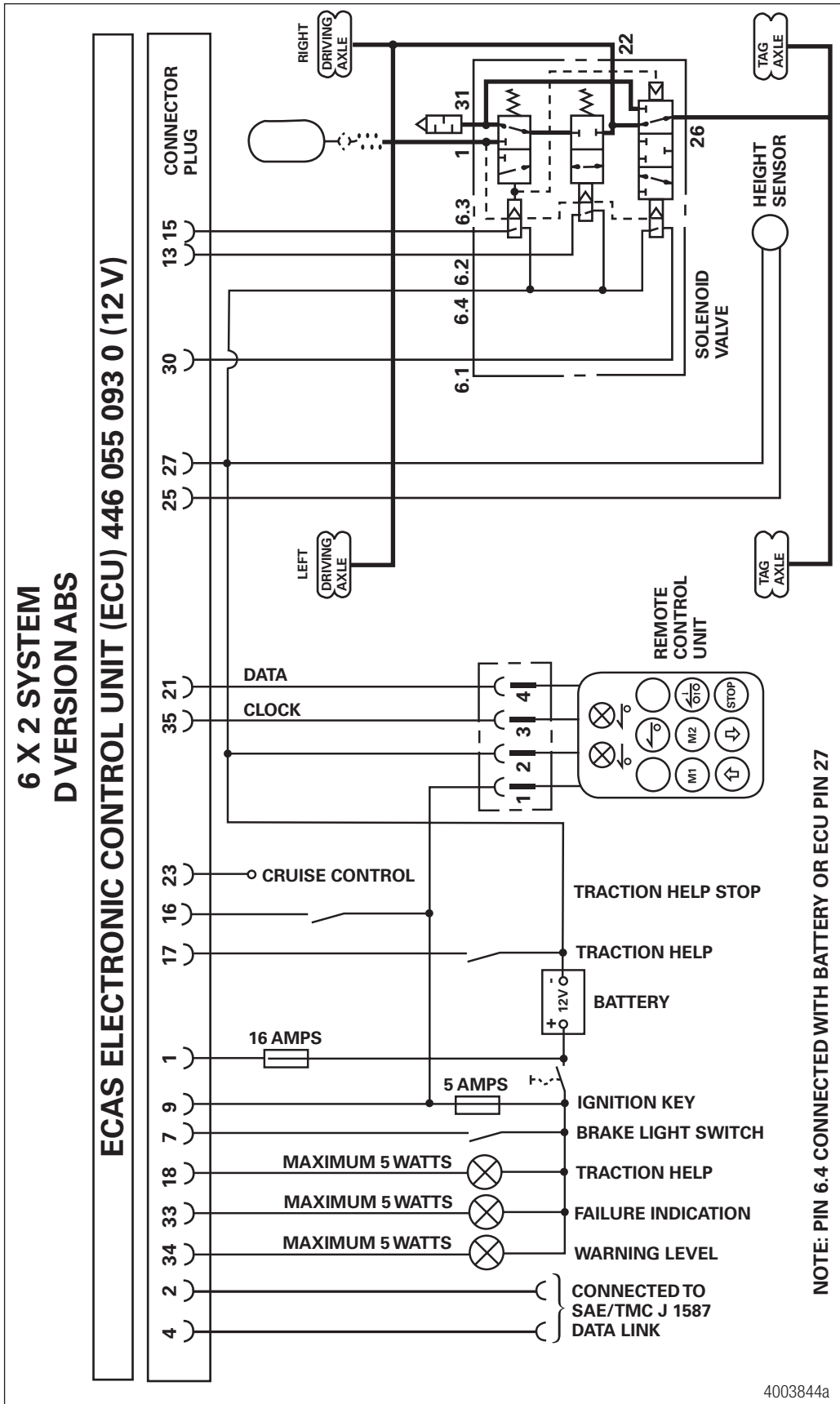

4003844a



# Wiring Diagrams

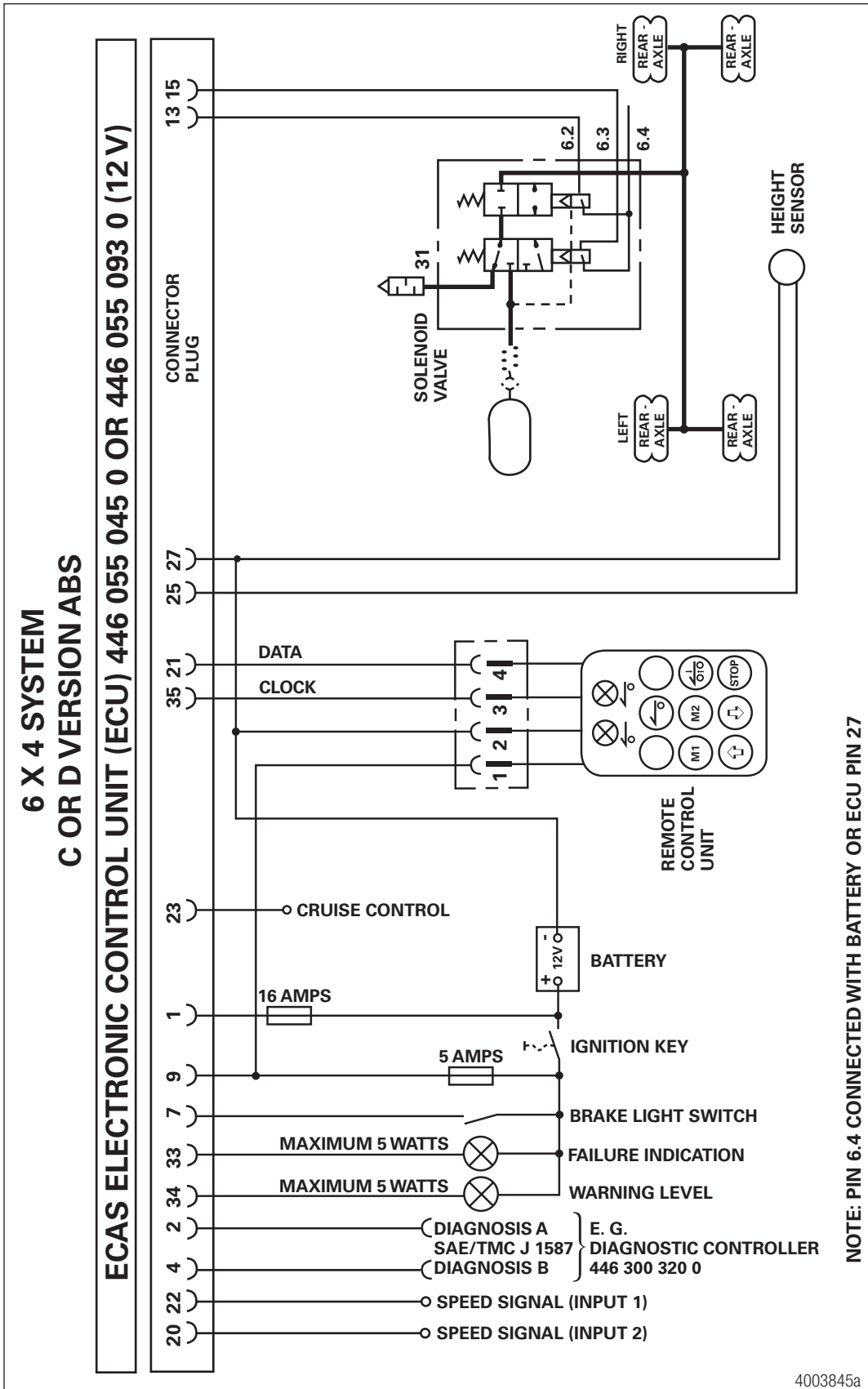

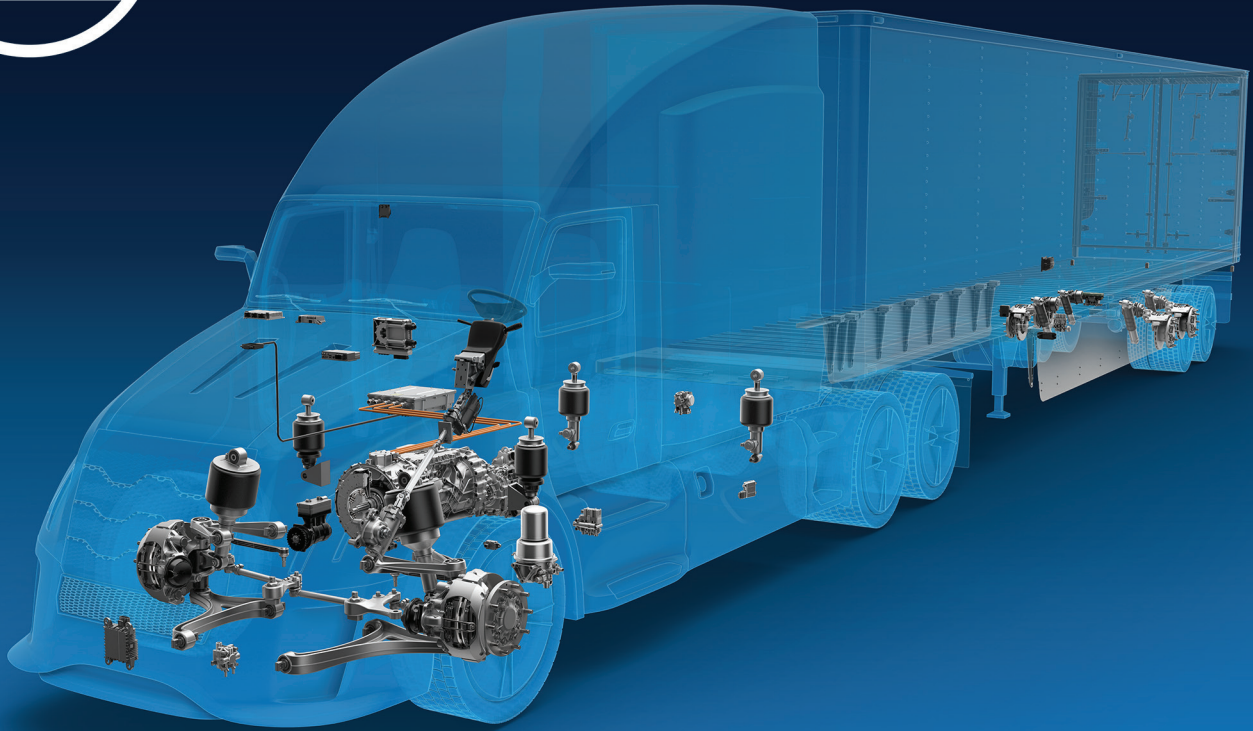

**For further details, contact the  
WABCO Customer Care Center at 855-228-3203.**

### **About CVS Division**

ZF's Commercial Vehicle Solutions (CVS) division is helping shape the future of commercial transportation ecosystems. Our mission is to be the preferred global technology partner to the commercial vehicle industry. Powerfully combining ZF's commercial vehicle systems expertise, extensive technology portfolio and global operations, the division serves the full commercial vehicle industry value chain. As the automotive industry progresses towards an increasingly autonomous, connected, and electrified (ACE) future, ZF's CVS division innovates, integrates and supplies components and advanced control systems that help make commercial vehicles and fleets operate more safely and sustainably. CVS unites ZF's former Commercial Vehicle Technology and Commercial Vehicle Control Systems divisions, the latter being formed following ZF's acquisition of WABCO in Spring 2020.

For more information, visit: [www.zf.com/cv](http://www.zf.com/cv)

**WABCO**